

**TILE COVERED PANEL**

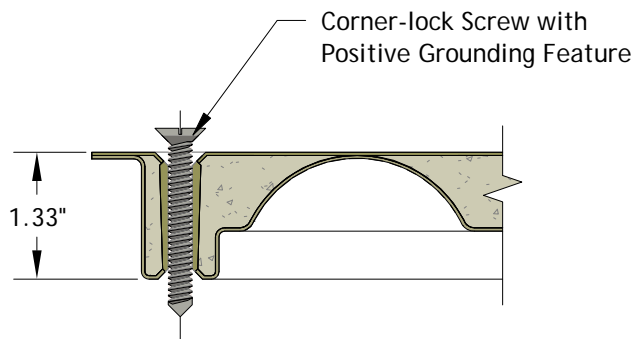

**BARE CORNER-LOCK PANEL**

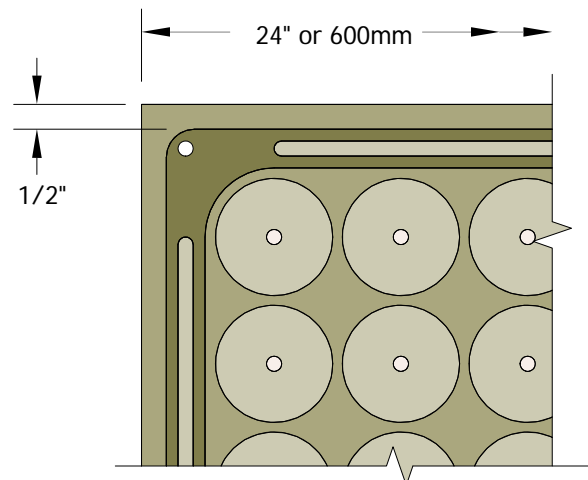

**PARTIAL BOTTOM VIEW**

## PHYSICAL DATA

- Weight of Bare Panel: 35 lb.
- Height of Bare Panel: 1.33"
- Fire Rating of Bare Panel:
  - Class A Flame Spread
  - Non-Combustible Materials

## PERFORMANCE DATA

- Concentrated Load Rating: 1,000 lbf (4.45 kN)
- Uniform Load Rating:
  - @ 0.040" Deflection: 460 psf (2245 kg/m<sup>2</sup>)
  - @ 0.060" Deflection: 580 psf (2831 kg/m<sup>2</sup>)
- Ultimate Load Rating:
  - Panel Only: 3,300 lbf (14.68 kN)
  - On Stringers: 3,700 lbf (16.46 kN)
  - Safety Factor: 3-to-1 Min.
- Impact Load Rating: 175 lb. (79 Kg)
- Rolling Load Rating:
  - Cisca Wheel A (10 Pass): 800 lbf (3.56 kN)
  - Cisca Wheel B (10K Pass): 600 lbf (2.67 kN)

## FINISH OPTIONS

- HPL Tile (1/16" or 1/8"):
  - ASM "Smart-Trim", "Dura-Trim", or "Mono"
- Vinyl Tile:
  - VPT "Con-Tile" (Static Conductive)
  - VPT "Stat-Tile" (Static Dissipative)
- RubberTile:
  - Antistatic
  - Standard
- Bare Surface
- Bare Corner-Lock
- Contact ASM for other tile options such as Bamboo, Cork, Ceramic, Wood, Stone, etc.

## UNDERSTRUCTURE OPTIONS

- Free Standing - Stringerless
- Corner-Lock
- Rigid Grid Bolted Stringers
  - 2' x 2' System
  - 2' x 4' System
  - 4' x 4' Basketweave System

## FEATURES

- Available in 24" or 600mm Size
- Powder Coat Epoxy Paint Finish
- Welded Steel Construction
- Full-Hard Steel Top Sheet
- Full-Strength, Deep Drawn Corners
- Light Weight Cementitious Fill with Fiberglass
- Recycled Material Content = 45.5%

NOTE: DATA SHEET DRAWING AND INFORMATION ARE SUBJECT TO CHANGE WITHOUT PRIOR NOTICE.