

Precision Cooling
For *Business-Critical Continuity™*

Liebert® DSE™ Precision Cooling System
Industry-best efficiency. Increased capacity. Ensured availability.

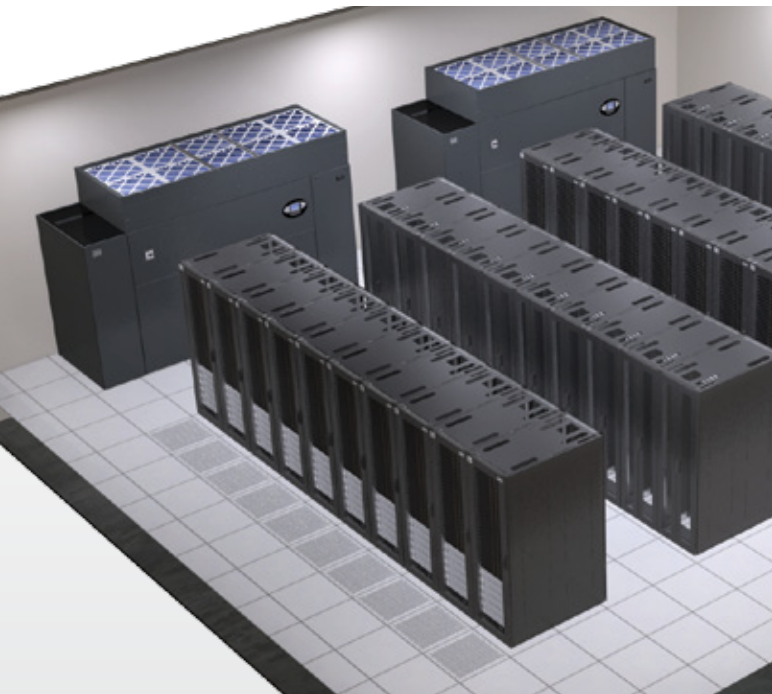

EFFICIENCY. CAPACITY. AVAILABILITY.

Liebert DSE High-Efficiency Precision Cooling System

Room-Based Precision Cooling for Consolidation and Efficiency

EFFICIENCY

Up to 70% more energy efficient than alternative technologies

Increasing the efficiency of your data center cooling infrastructure is one of the most effective ways to decrease your data center utility spending. The Liebert DSE high efficiency precision cooling system from Emerson Network Power combines the industry's highest efficiency operation – up to 70% more efficient than alternative technologies – with the reliability and local expertise associated with Liebert products.

The Liebert DSE high-efficiency precision cooling system is designed from the ground up to help solve the problems that IT departments face every day. Offered in air-cooled models, the Liebert DSE high-efficiency precision cooling system ensures the availability and capacity that today's IT climate demands while still cutting energy costs and lowering PUE.

This cooling solution is scalable, ensuring that the data center receives the right amount of cooling year-round, and also accommodating future growth and changing data center loads.

Key applications

The Liebert DSE precision cooling system provides the industry's highest efficiency for:

- Data centers suffering from increased heat density, and the resulting higher cooling power consumption
- IT managers who want to reduce cooling costs and power usage
- Organizations interested in installing fewer high capacity systems as opposed to more lower capacity cooling systems

Typical Precision Cooling System Energy Usage By Component

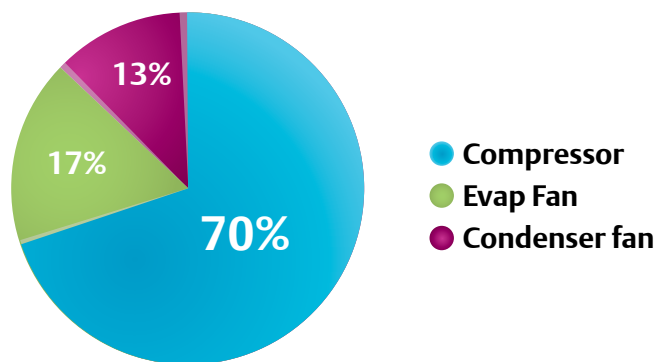

Liebert DSE uses energy saving components such as digital scroll compressors, EC fans and microchannel condensers to optimize component usage through free cooling and variable capacity operation.

A Tradition of Efficiency, Reliability and Availability

Emerson Network Power's Liebert precision cooling equipment is the standard by which all others are judged. The number of our units that are in the field far exceeds the combined number of all other brands. Nine out of ten Fortune 500 Companies have entrusted Liebert precision cooling systems to support their IT infrastructure.

Our precision cooling systems are used in the most demanding applications in the world. From banking to government to corporate computer and communications centers, when it has to be the best—this is the brand of choice for mission-critical continuity.

Meet Government and Industry Standards in Efficiency with the Liebert DSE

EFFICIENCY

The Liebert DSE high-efficiency precision cooling system far exceeds ASHRAE 90.1 – the industry standard for energy efficiency in cooling equipment. This standard has even been adopted as energy code in most states. By using the Liebert DSE, you can ensure that your data center meets ASHRAE standards and position your organization as an industry-leader in environmentally friendly and cost-effective cooling.

Air-Cooled Systems Designed to Operate Efficiently in Every Climate

The Liebert DSE utilizes these innovative technologies to deliver cost-savings and meet standards in efficiency:

- Tandem digital scroll compressors
- EC plug fans
- Staged evaporator coil
- Electronic expansion valves
- Liebert EconoPhase™ Pumped Refrigerant Economizer
- Liebert iCOM® control

Energy Efficiency (SCOP)

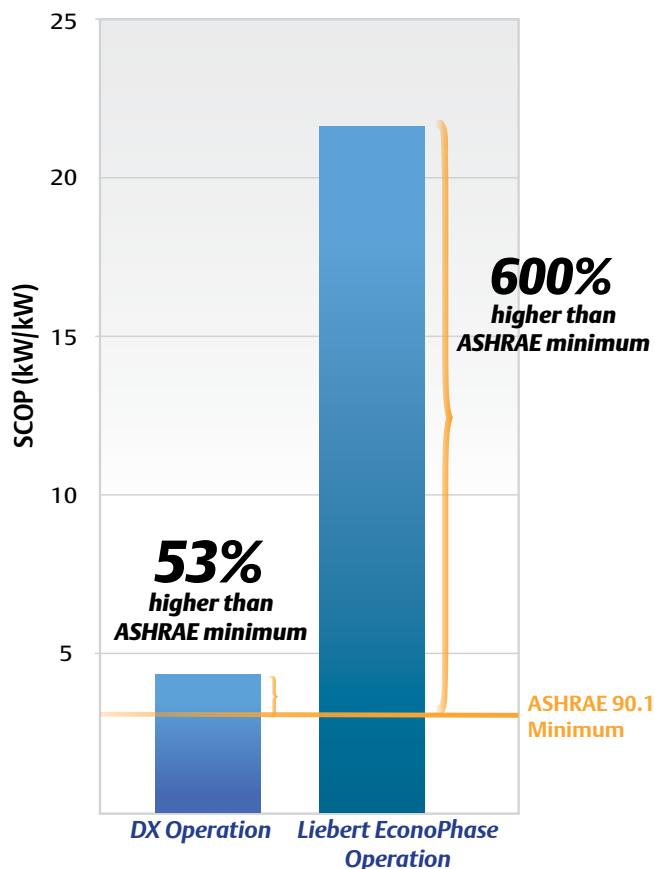

Laboratory tested to ASHRAE127. Sensible Co-efficient of Performance (SCOP): Energy efficiency @100% load and 95°F outdoor ambient , 75°F return air

Liebert MC Condensers

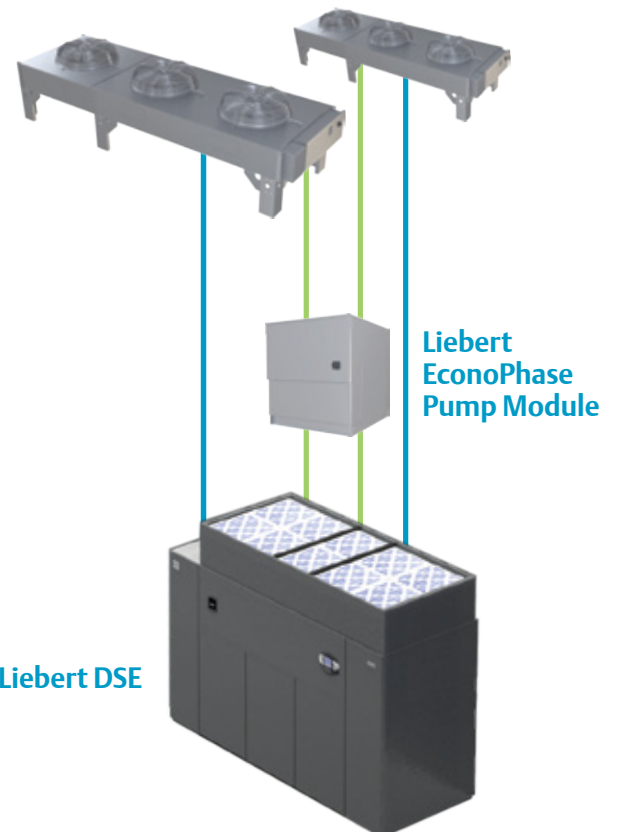

Optimize Efficiency through Scalability and Control

SCALABILITY

Innovative application of patented technologies allows the Liebert® DSE™ to scale compressor, fan and coil operation according to the data center load. This eliminates overcooling and unnecessary energy consumption, and allows the system to operate efficiently at both partial and full cooling load conditions.

This precision cooling solution utilizes scalable components such as variable capacity compressors and condensers to ensure that cooling output directly corresponds to the demands of the IT and networking systems. When Liebert DSE is equipped with the EconoPhase™ Pumped Refrigerant Economizer, Liebert iCOM® controls will determine when outdoor ambient conditions are suitable for transfer to economizer, allowing optimized operation for higher efficiency.

Consolidate Your Cooling

Consolidating cooling equipment can make your data center perform more efficiently and free up space. The 125kW Liebert DSE is capable of handling the workload typically performed by several smaller, lower capacity cooling units, providing a solution that can free up floor space and reduce system complexity for service, maintenance and parts.

Using Liebert DSE instead of multiple lower capacity, lower efficiency systems can create considerable energy and operational savings.

PUE and Energy Savings with the Liebert DSE

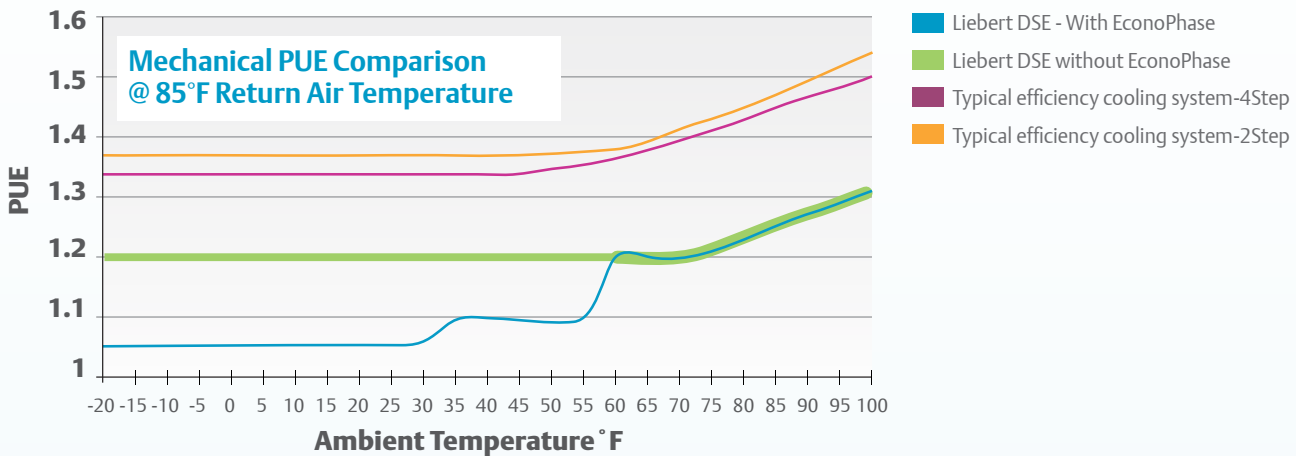

City	Typical 2-Step CRAC		Typical 4-Step CRAC		Liebert DSE	
	PUE	Annual Energy	PUE	Annual Energy	PUE	Annual Energy
Columbus	1.39	\$340,860	1.36	\$316,615	1.13	\$117,606
Minneapolis	1.39	\$337,586	1.36	\$312,659	1.12	\$105,572
Dallas	1.41	\$361,841	1.39	\$339,045	1.18	\$156,041
Orlando	1.42	\$366,219	1.39	\$345,808	1.20	\$172,371
San Francisco	1.38	\$334,057	1.35	\$309,078	1.13	\$114,293
Phoenix	1.43	\$380,544	1.41	\$356,578	1.21	\$179,544

Liebert DSE and Liebert EconoPhase Pumped Refrigerant Economizer drastically improve operating PUE over typical cooling solutions. These improvements also result in energy savings of \$200,000 and more, based on geographical location and Liebert EconoPhase usage.

Mechanical Power Usage Effectiveness (Mechanical PUE) equals cooling capacity plus input power) divided by cooling capacity.

1,000 kW Load, \$0.10 per kWhr, 70% load

Introducing Liebert® EconoPhase™ Pumped Refrigerant Economizer



The Liebert DSE™ air cooled model can utilize the Liebert EconoPhase pumped refrigerant economizer. This economizer provides one of the simplest cooling solutions available. Control is integral to the unit, and eliminates the risks of some economizer approaches during transition to and from the “free-cooling” mode of operation.

The Liebert EconoPhase pumped refrigerant economizer ensures efficiency and cost-savings while maintaining simplicity of installation – and it’s only available with the Liebert DSE.

Advantages of Liebert EconoPhase vs. other “free-cooling” approaches:

- Avoid the cost of water
- Avoid the cost of treating water
- Avoid the complexities of starting a chiller with cold condensing water
- Instant, automatic transition provides the ability to make use of 100% of available economization hours
- Keep your vapor barrier intact
- No limitation on operation when humidity is very low
- Minimizes risk of gaseous contamination impacting IT gear

Liebert EconoPhase Efficiency 70% load, 25°F Ambient

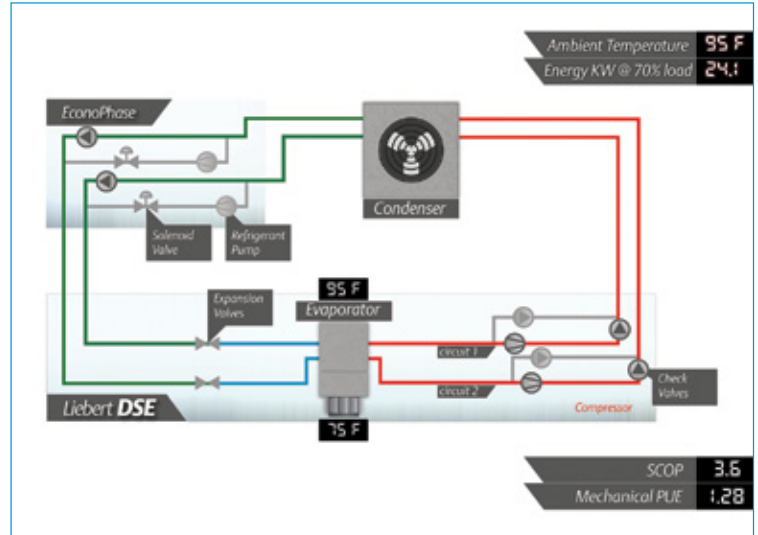
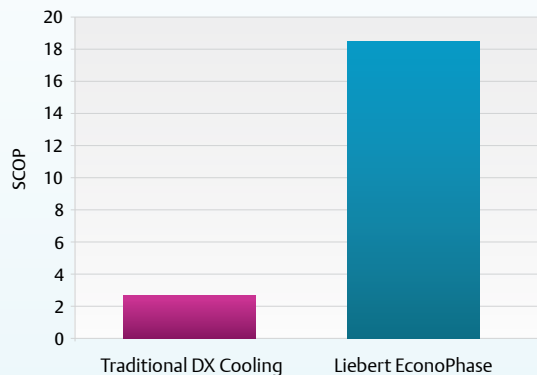

Summer Time Operation

Even during summer time operation, the Liebert DSE is 40% more efficient than historic data center cooling systems. Energy savings are significant.

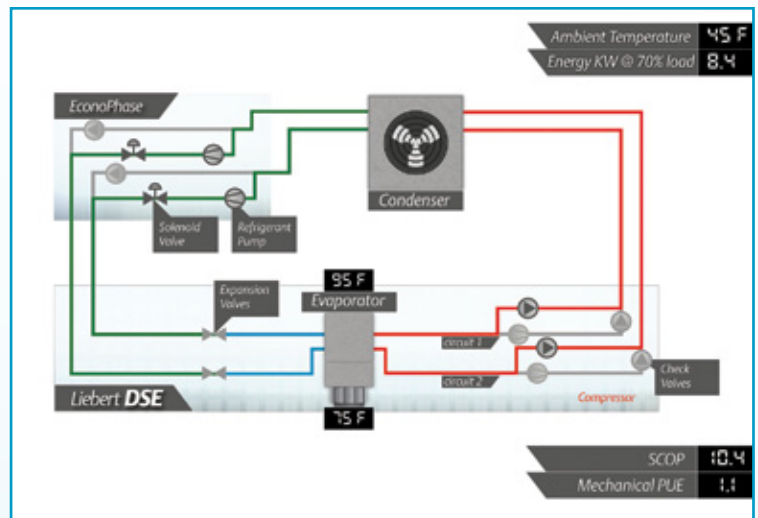

Night Time or Winter Operation

During full Liebert EconoPhase economizer operation, the Liebert DSE is up to 1000% more efficient than historic data center cooling systems. Energy savings far exceed any system in the industry.

Ensuring Availability and Reliability with Innovative Technology

AVAILABILITY

Business-critical systems demand availability and capacity. However, to keep costs down, data center managers must constantly strive to maximize efficiency in their infrastructure equipment.

The Liebert® DSE™ precision cooling system utilizes innovative equipment that is designed to ensure reliability and performance while operating at the industry's highest efficiency. The Liebert DSE can create savings of 70% or greater compared to traditional perimeter precision cooling systems at the design-day rating point.

The Liebert DSE uses the following primary innovations to ensure efficiency, availability and capacity:

- Tandem digital scroll compressors
- EC plug fans
- Staged evaporator coil
- Electronic expansion valves
- Liebert EconoPhase™ Pumped Refrigerant Economizer
- Liebert iCOM® control
- Micro-channel coil condenser with intelligent EC fans



1 Liebert EconoPhase Pumped Refrigerant Economizer (Air models only)

The air-cooled Liebert DSE precision cooling system is available with an optional Liebert EconoPhase pumped refrigerant economizer, which uses cooler outdoor temperatures to enable “free-cooling”. This is a fluid economizer that utilizes the system’s R410 refrigerant as the fluid in the same evaporator/condenser coils as normal operation. The two-phase characteristic of the fluid is over 9 times better at transporting heat as the glycol mixtures typically found with compressorized solutions. The lack of need for a special econo-coil also saves evaporator fan energy.

This revolutionary economizer makes the Liebert DSE with Liebert EconoPhase more efficient than a Chiller Plant with a series “free-cooling” heat exchanger, and it is also more efficient than an air economizer “free-cooling” system. This higher efficiency is gained while also eliminating the risks and maintenance issues faced by other “free-cooling” approaches.

2 **Electronic expansion valves**, used in place of mechanical thermal expansion valves, enable operation at lower condensing temperatures, which reduces compressor power and improves efficiency.

3 **EC Plug Fans** are designed to function optimally both in the unit and under the floor. This makes the Liebert DSE system a great fit for both raised floor and non-raised floor data centers.

EC Plug Fans operate at variable speeds, ensuring that performance is matched to load for the greatest efficiency.

4 **Staged evaporator coils** provide greater efficiency when only one circuit of cooling is required.

5 **Tandem digital scroll compressors** reduce power consumption as cooling capacity is modulated. This allows the Liebert DSE high-efficiency precision cooling system to consume the proportionate amount of power for the load.

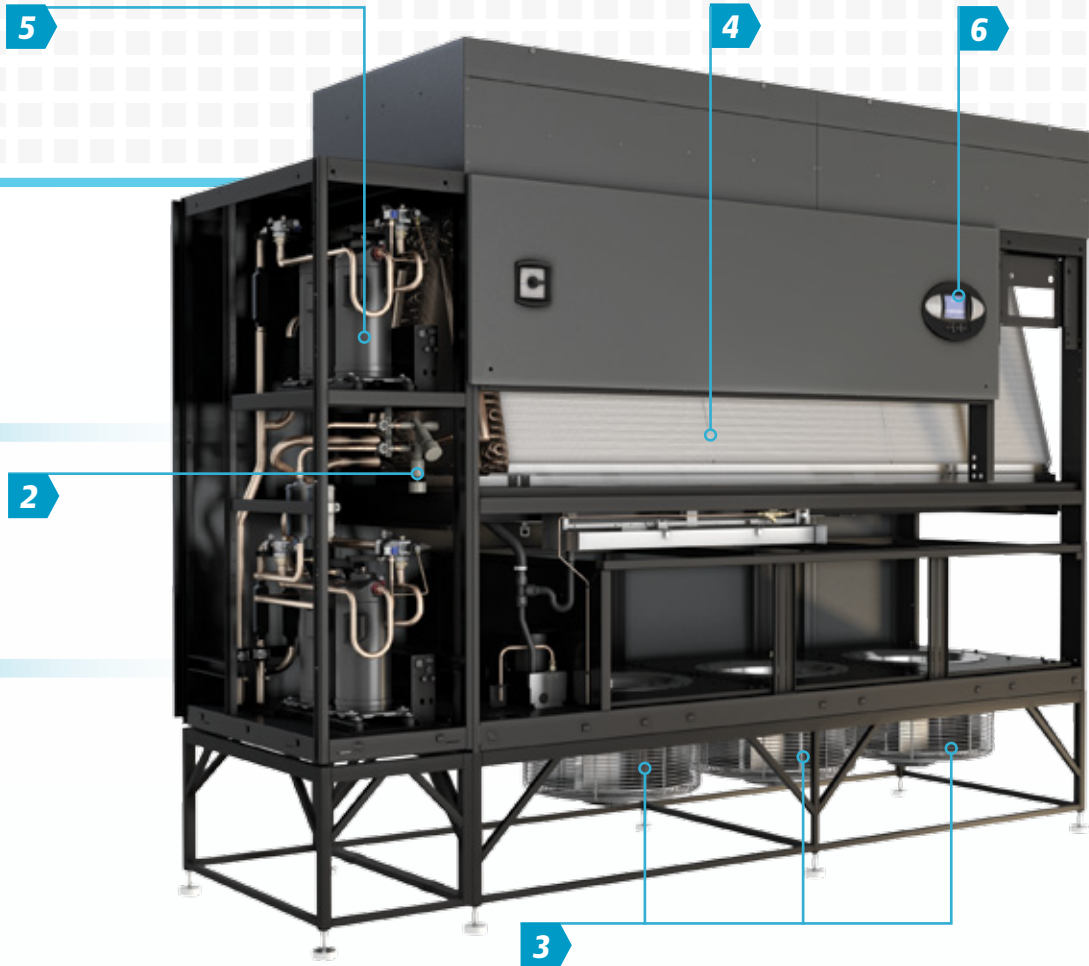

6 Optimize efficiency and reliability with the Liebert® iCOM™ Control

The Liebert iCOM control, integrated into every Liebert DSE™, ensures that all cooling units in a data center are operating together intelligently to achieve maximum efficiency. The control monitors temperature and humidity levels throughout the room, calculating the most effective way to optimize operation and efficiency. With the Liebert iCOM control, you can take advantage of:

- Energy savings using predictive humidity control
- Enhanced system reliability through built-in lead/lag functions
- Unit-to-unit communications with teamwork settings to keep multiple units working together to optimize energy efficiency
- Precise control of temperature and airflow in the cold aisle



Increase Visibility, Availability and Efficiency with Centralized Monitoring Technologies

VISIBILITY

Emerson Network Power provides solutions that allow data center managers to easily monitor, manage and control their IT equipment from a centralized dashboard or interface and via remote access. Our monitoring solutions also allow for the creation of detailed analytics and reports. Using these technologies, you can proactively ensure your data center operations are secure, stable and cost-effective.

Here are a few examples of our monitoring technology solutions that can be paired with the Liebert® DSE™ high-efficiency precision cooling system to optimize your operations:

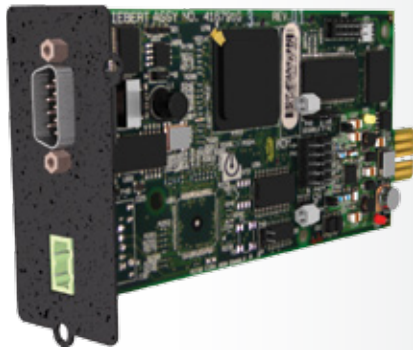

Liebert IntelliSlot 485 Communication Card

The Liebert IntelliSlot 485 Card w/Adapter provides Liebert SiteScan Web or Building Management Systems monitoring and control of your UPS. The card delivers Modbus or Liebert Proprietary protocol via the EIA-485 port. The Liebert IntelliSlot Web/485 Card with Adapter bridges the gap between Network and Building Management systems with its ability to communicate to BMS systems with Modbus, as well as communicating to NMS systems through SNMP and Web. All interfaces can operate concurrently..

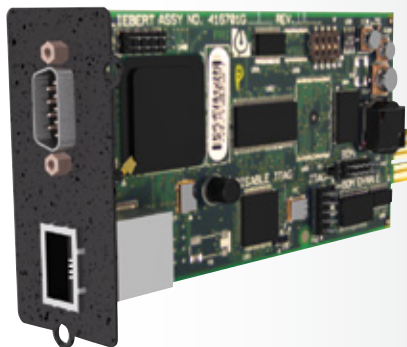

Liebert IntelliSlot Web Card

The Liebert IntelliSlot Web Card communicates to network Management Systems SNMP. As the name infers, the card also produces a Web page which allows users to get real-time data through their Internet browser.



Centralized Management with Liebert® Nform™ Software:

As business grows, your critical equipment infrastructure will expand, thus the need for centralized management of this equipment will be key to your business success. Liebert Nform leverages the network connectivity capabilities of your Liebert equipment to provide a centralized view of your distributed equipment. By utilizing Liebert Nform, you can further optimize the Liebert DSE™ high-efficiency precision cooling system by leveraging its interoperability with other infrastructure equipment to ensure optimal IT conditions and prevent downtime.

Utilizing the SNMP and Web technologies built into each of the Liebert IntelliSlot communication cards, Nform will centrally manage alarm notifications to provide you with an easy interface to access critical status information from your Liebert DSE and other mission-critical equipment.

Liebert Nform puts critical systems information at the fingertips of support personnel—wherever they are—increasing responsiveness to alarm event conditions, thus allowing IT organizations to maximize their system availability.



Liebert SiteScan Web Enterprise Management with Liebert SiteScan® Web Software

For customers who require extensive management of critical system equipment that may span multiple locations in an ever-moving global enterprise, Liebert SiteScan Web will centrally manage your Liebert DSE and other infrastructure equipment and give you the power to move beyond the event-responsive service paradigm.

Liebert SiteScan Web does it all:

- Real-time monitoring and control
- Event management and reporting
- Data analysis and trending
- Building management integration

Liebert SiteScanWeb is a comprehensive critical systems management solution dedicated to ensuring reliability through graphics, event management and data extrapolation. The standard Web interface allows users easy access to the Liebert DSE and other IT equipment from anywhere at any time.

- Single- and multi-site applications
- Event management and unit control
- Trend and historical data captures and reporting
- Full ASHRAE BACnet compatibility
- Java based

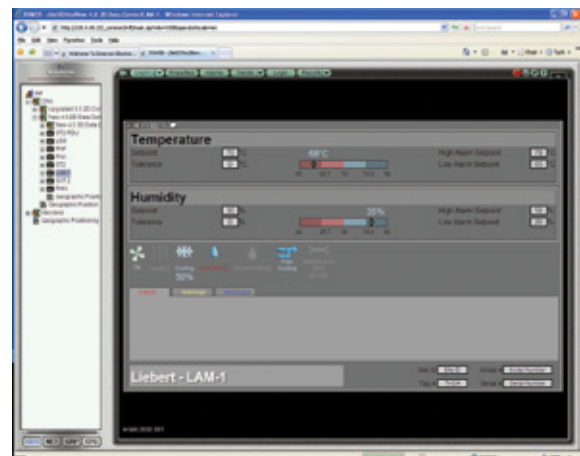

Industry Best Service, Support and Expertise

Emerson Network Power is the industry leader in mission-critical continuity. Our local technicians and representatives are always on hand to help deal with any equipment issues that arise. Emerson Network Power staff can provide the service, support and expertise that your data centers needs.



Our locally-based experts are also readily available to provide guidance in the design and development of your IT infrastructure. We will work together with you and your staff to create a solution that maximizes your investment in efficiency, availability and capacity.

When you partner with Emerson Network Power, you are positioned to benefit from:

- A nation-wide network of local data center design experts
- Unbeatable dedication to service and support
- Rapid response times
- Design, development and efficiency guidance and expertise

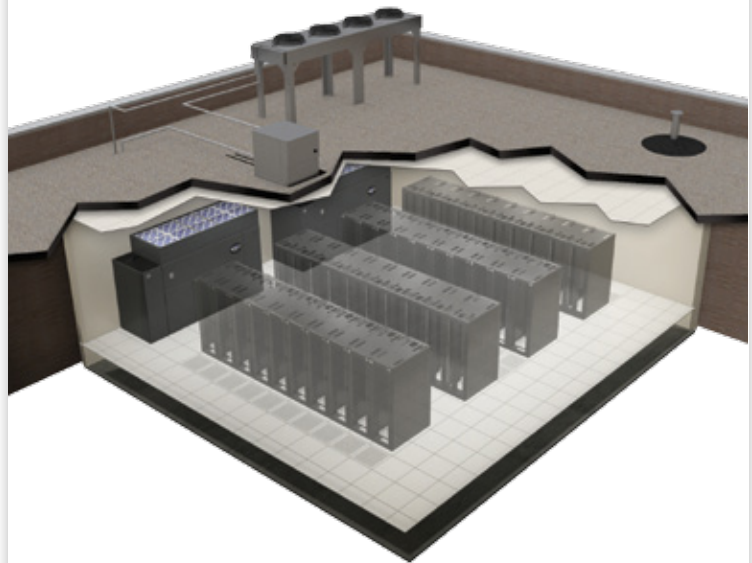

Liebert DSE can support room cooling from the perimeter of the data center...or can be installed in a gallery, with air ducted into the IT space.

Specifications

Liebert® DSE™

Return Air 85°F

95°F DB, 67.7°F WB, 52.3°F DP (35°C DB, 19.8°C WB) 24% RH	80	85	125	150
Total kW	88	100	146	170
Sensible kW	84	94	146	170
Compressor Mode: Net Full-load PPUE / SCOP (kW/kW) @ 95°F Outdoor Ambient	1.31 / 3.2	1.32 / 3.1	1.26 / 3.8	1.31 / 3.2
Pump Mode: Net Full-load PPUE / SCOP (kW/kW) @ 35°F Outdoor Ambient	1.10 / 10.5	1.10 / 10.1	1.06 / 17.5	1.08 / 13
85°F DB, 64.5°F WB, 52.3°F DP (29.4°C DB, 18.1°C WB) 32% RH	80	85	125	150
Total kW	85	92	130	153
Sensible kW	77	83	130	153
Compressor Mode: Net Full-load PPUE / SCOP (kW/kW) @ 95°F Outdoor Ambient	1.33 / 3.0	1.37 / 2.7	1.29 / 3.4	1.34 / 2.9
Pump Mode: Net Full-load PPUE / SCOP (kW/kW) @ 35°F Outdoor Ambient	1.11 / 9.1	1.11 / 8.7	1.08 / 12.2	1.08 / 12
75°F DB, 61.1°F WB, 52.3°F DP (23.9°C DB, 16.2°C WB) 45% RH	80	85	125	150
Total kW	75	86	116	134
Sensible kW	67	73	112	134
Compressor Mode: Net Full-load PPUE / SCOP (kW/kW) @ 95°F Outdoor Ambient	1.38 / 2.6	1.42 / 2.4	1.33 / 3	1.42 / 2.4
Pump Mode: Net Full-load PPUE / SCOP (kW/kW) @ 35°F Outdoor Ambient	1.13 / 7.5	1.14 / 7.2	1.09 / 10.7	1.10 / 10.2

DRY WEIGHT		DIMENSIONAL DATA				
Model	Weight lb (kg)	Depth in (mm)	Width in (mm)	Height in (mm)		
				Base unit	Plenum	Total
DA080	2200 (998)	100 (2540)	35 (889)	76 (1930)	N/A	76(1930)
DA085	2250 (1021)	100 (2540)	35 (889)		N/A	76(1930)
DA125	3465 (1572)	47 (1194)	144 (3658)		18 (457)	94 (2388)
DA150	3565 (1617)	47 (1194)	144 (3658)		18 (457)	94 (2388)

Liebert EconoPhase™ Specs shown are DA125 with PR125

Liebert EconoPhase Performance - 80% Load							DIMENSIONAL DATA	
Outdoor Ambient, °F	Return Air DB, °F	Cooling Mode	Net Sensible capacity kW	Total System Power kW	SCOP	pPUE*	Net Weight lb (kg)	Dimensions (L x W x H) in (mm)
70	85	Compressor	100.8	21.3	4.7	1.21		
60	85	Mixed	100.8	17.1	5.9	1.17		
50	85	Pump	100.8	9.7	10.4	1.10		
25	85	Pump	100.8	5.2	19.5	1.05		

* pPUE refers to "partial" Power Usage Effectiveness, or PUE for cooling only.
pPUE = (Sensible Capacity + Input Power) / Sensible Capacity

Emerson Network Power, a business of Emerson (NYSE:EMR), is the global leader in enabling *Business-Critical Continuity™* from grid to chip for telecommunication networks, data centers, health care and industrial facilities. Emerson Network Power provides innovative solutions and expertise in areas including AC and DC power and precision cooling systems, embedded computing and power, integrated racks and enclosures, power switching and controls, monitoring, and connectivity. All solutions are supported globally by local Emerson Network Power service technicians. Liebert AC power, precision cooling and monitoring products and services from Emerson Network Power deliver *Efficiency Without Compromise™* by helping customers optimize their data center infrastructure to reduce costs and deliver high availability.

**Emerson Network Power
Liebert Corporation World Headquarters**

1050 Dearborn Drive
P.O. Box 29186
Columbus, Ohio 43229
United States Of America
800 877 9222 Phone (U.S. & Canada Only)
614 888 0246 Phone (Outside U.S.)
614 841 6022 FAX
Contact@EmersonNetworkPower.com

**Emerson Network Power
Caribbean and Latin America**

Office – United States of America
+1-954-984-3452 Phone
Ask.Cala@Emerson.com

**Emerson Network Power
European Headquarters**

Office – Italy
+39 049 9719 111 Phone
+39 049 5841 257 FAX
Marketing.EMEA@EmersonNetworkPower.com

**liebert.com
24 x 7 Tech Support**

800 222 5877 Phone
614 841 6755 (outside U.S.)

While every precaution has been taken to ensure accuracy and completeness in this literature, Liebert Corporation assumes no responsibility, and disclaims all liability for damages resulting from use of this information or for any errors or omissions.

© 2013 Liebert Corporation. All rights reserved throughout the world. Specifications subject to change without notice.

All names referred to are trademarks or registered trademarks of their respective owners.

® Liebert is a registered trademark of the Liebert Corporation.

SL-18927 (R03/13) Printed in USA

Emerson Network Power.

The global leader in enabling *Business-Critical Continuity™*.

- AC Power
- Embedded Computing
- Outside Plant
- Racks & Integrated Cabinets
- Connectivity
- Embedded Power
- Power Switching & Controls
- Services
- DC Power
- Infrastructure Management & Monitoring
- Precision Cooling
- Surge Protection