

Part Number: **Leak Detection**



Description

Detect moisture over a wide area. This cable detects the presence of water or other conductive liquid over its entire length. Typically used to protect computer server rooms from water damage, the leak detection kit attaches to a climate monitor. When water is detected, the climate monitor sends alerts by e-mail or SNMP trap.

- Use this water sensing cable to detect leaks
- Connects to a climate monitor via Analog Input or CCAT
- Get alerts by e-mail or SNMP if water is detected

Features

Specifications:

- Connector: 2 position screw terminal block
- Input rating: 0 to 5VDC signal or dry contact
- Cable type: Cat-3 with RJ-12 connector
- Cable length: 12', 25' or custom
- Warranty: 1 year

Compatibility:

- Works with all climate/power monitors with analog ports
- Climate monitors support up to 16 digital sensors, limit of 600' total aggregate cable length

Water Snake Kit with 10 ft. cable: WSCK-10 (11936)

Water Snake Kit with 40 ft. cable: WSKC-40 (11937)

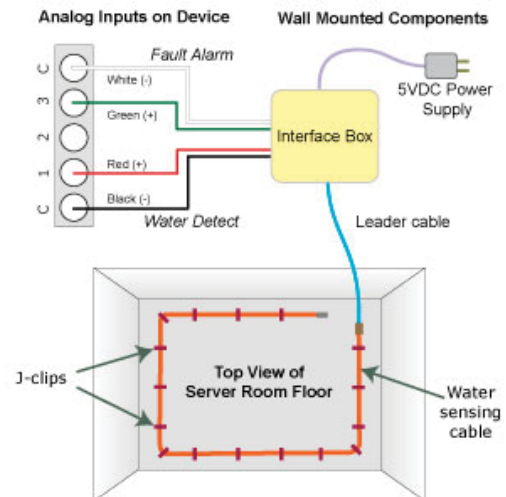

Please note the information contained herein is for informational purposes only. Technical claims listed depend on a series of technical assumptions. Your experience with these products may differ if you operate the products in an environment, which is different from the technical assumptions. Geist reserves the right to modify these specifications without prior notice. Geist makes no warranties, express or implied, on the information contained in this document.

Geist Americas

1821 Yolande Ave
Lincoln, NE 68521 USA
1.800.432.3219 or
1.402.474.3400
www.geistglobal.com

Geist DCiM
2290 E Prospect Rd.
Fort Collins, CO 80525 USA
1.877.449.4150
www.geistglobal.com

Geist Europe

Unit 1, The Monarch Centre,
Ventruie Way,
Priorswood, Taunton,
Somerset, TA2 8DE UK
+44 (0) 1823 275100
www.geisteurope.com

Geist Asia

China
Tiley Plaza, Unit #2808,
No. 199 Haide 3 Road
Nanshan Shenzhen
Guangdong Province China
Postal Code: 518000
Tel: +86.755.86639505
www.geistglobal.com

Hong Kong
Tel: +852 90361927
Email: salesasia@geistglobal.com
www.geistglobal.com