

INSTALLER'S CHOICE™

better built by design

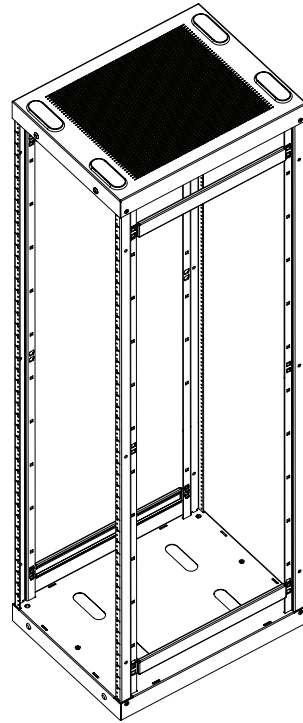

Model Numbers

SR43	SR43-26 - Load Rating - 600 Lbs.
SR37	SR37-26 - Load Rating - 600 Lbs.
SR29	SR29-26 - Load Rating - 600 Lbs.
SR21	SR21-26 - Load Rating - 500 Lbs.
SR14	SR14-26 - Load Rating - 300 Lbs.
SR8	SR8-26 - Load Rating - 200 Lbs.

Components and Supplied Hardware

Top

SR-T	A (4) #1/4-20 x 1/2" Flat Head Socket Screws
SR-T-26	B (1) 5/32 Hex Wrench

Base

SR-B	A (4) #1/4-20 x 1/2" Flat Head Socket Screws
SR-B-26	B (1) 5/32 Hex Wrench

Main Rails

SR43-R	(125) #10-32 x 1/2" Self-Tapping Screws
SR37-R	(100) #10-32 x 1/2" Self-Tapping Screws
SR29-R	(75) #10-32 x 1/2" Self-Tapping Screws
SR21-R	(75) #10-32 x 1/2" Self-Tapping Screws
SR14-R	(50) #10-32 x 1/2" Self-Tapping Screws
SR8-R	(25) #10-32 x 1/2" Self-Tapping Screws

Please read INSTALLER'S CHOICE™ SnapRax Instructions BEFORE Installation

Assembly Instructions

IMS EP Installer's Choice™ has provided assembly instructions with the goal to make this assembly as easy and complete as possible. IMS EP Installer's Choice™ makes no claim that the information contained herein covers all details, conditions, or variations. It also does not provide for each and every possible incident in connection with the installation or use of this product. IMS EP Installer's Choice™ reserves the right to make information/product changes as required without prior notification. IMS EP Installer's Choice™ makes no statement of warranty (expressed or implied), regarding the information contained herein. IMS EP Installer's Choice™ assumes no responsibility for accuracy, completeness or sufficiency of the information contained in this document.

Final installation of equipment into the enclosure (SnapRack) system will be performed by qualified personnel in accordance with NFPA70, National Electrical Code (NEC). The SnapRack is intended to be used with UL Listed product.

Not for use in a computer room as defined in the Standard for the Protection of Electronic Computer/ Data Processing Equipment, ANSI/NFPA 75.



Do not use this product for any purpose not explicitly specified by Installer's Choice™.

The size and weight of your rack/component mount equipment must not exceed the stated weight loads established for each Installer's Choice™ model.

Failure to comply with these requirements could result in serious injury or property damage. If you do not understand these directions, or have doubts about the safety of the installation, contact Installer's Choice™ Customer Service @ 847-391-8100.

Installer's Choice™ is not liable for damage/injury caused by incorrect mounting, assembly, or use.

Supplied Parts and Instructions

Before starting installation, please read ALL instructions carefully. Verify all parts are included and undamaged. If any parts are missing or damaged, do not return the item to your dealer/installer-contact Installer's Choice™ Customer Service at 847-391-8100.

Warranty

This warranty is provided in goodwill and extends only to the original purchaser of the IMS EP Installer's Choice SnapRax product; it is non-transferable. This warranty is automatically void if your Installer's Choice SnapRax product is modified in any way: improperly installed, extended beyond its stated weight capacity or otherwise misused or abused. This warranty cannot be transferred over or extended to anyone other than the original purchaser. The ten-year warranty for all SnapRax and SnapRax-related products is void if the rack is altered or modified in any way, shape or form.

Installer's Choice disclaims any other warranties, express or implied- including warranties of fitness for a particular purpose and warranties of merchantability- to the maximum extent permitted by law. Installer's Choice is not liable for any damages whatsoever arising from the use of or inability to use its products, even if Installer's Choice has been advised of the possibility of such damages. Installer's Choice disclaims any responsibility for incidental or consequential damages to the maximum extent permitted by law.

Assembly Instructions for SnapRax

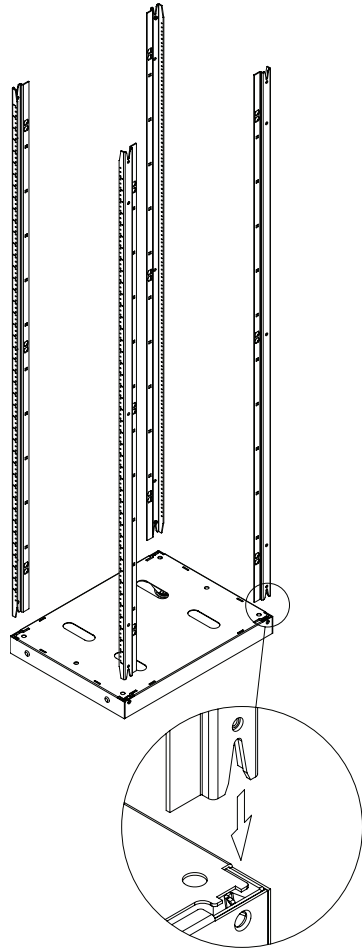

Step 1
(Base)

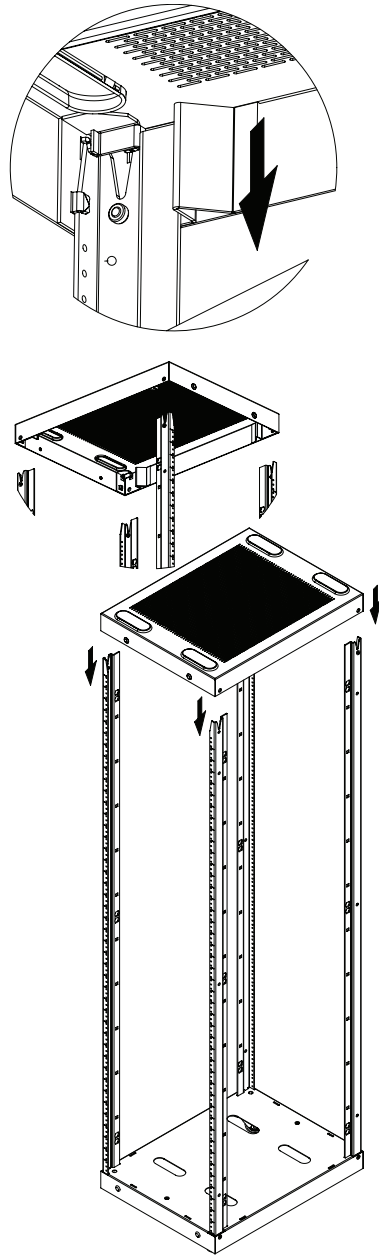

Step 2
(Top)

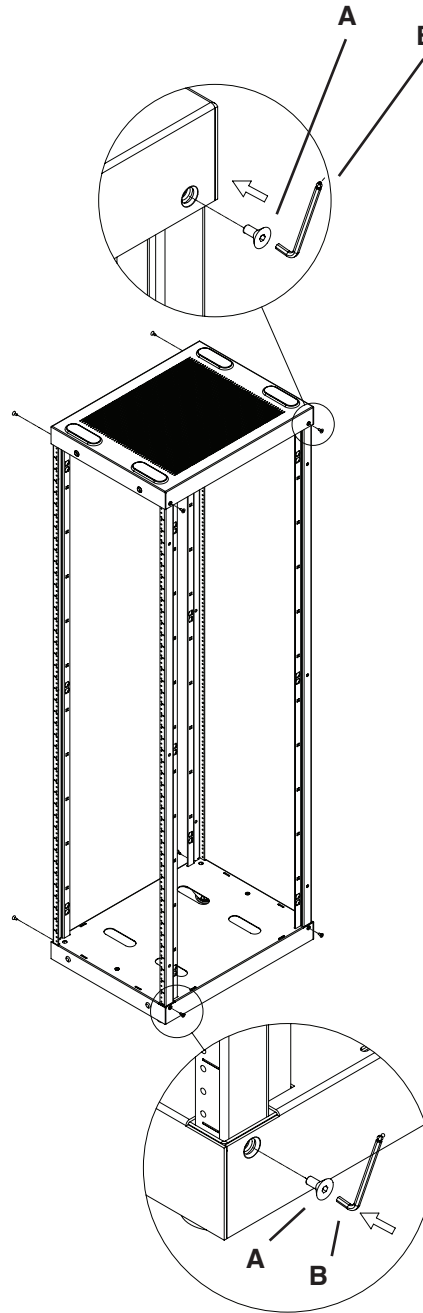

Step 3

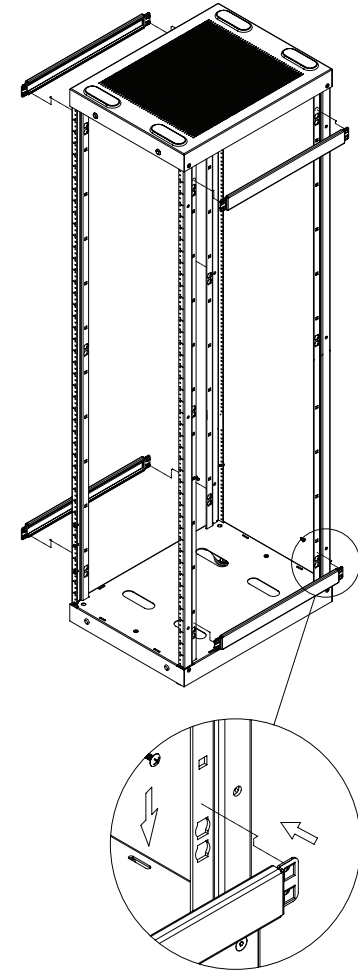

Step 4