

## CABINET DIMENSIONAL DATA

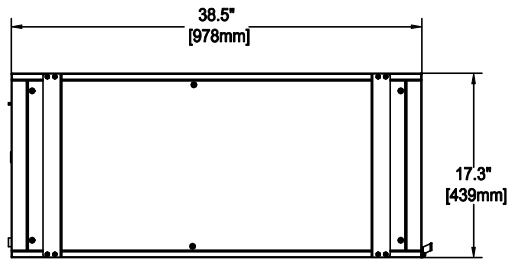

Left Side of Unit

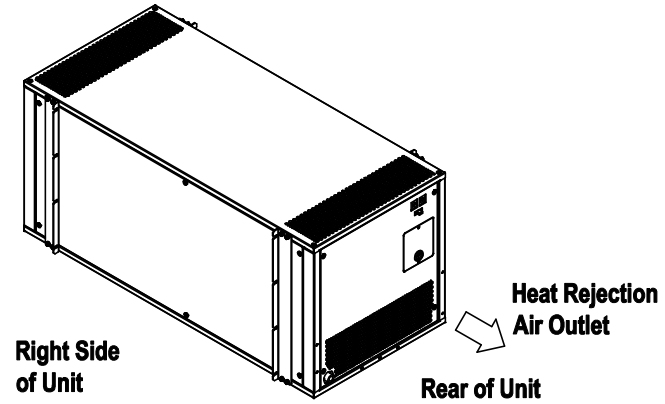
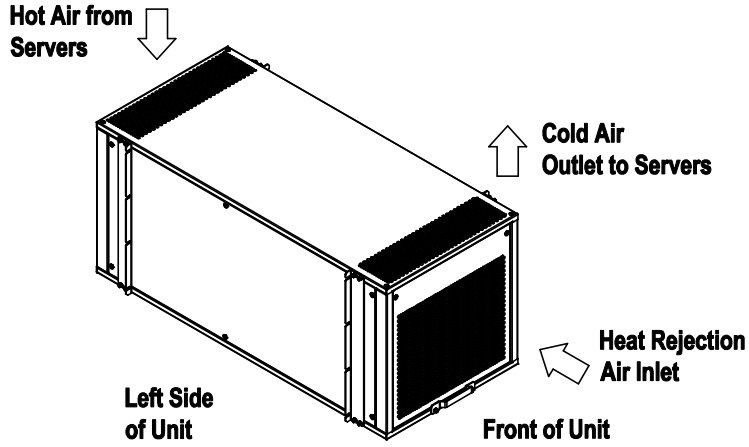
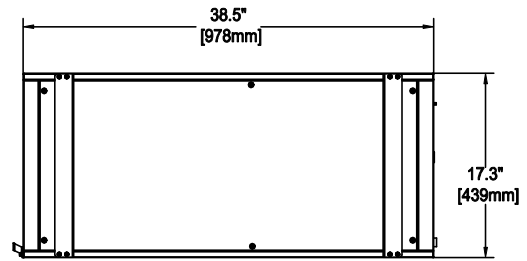

Right Side of Unit

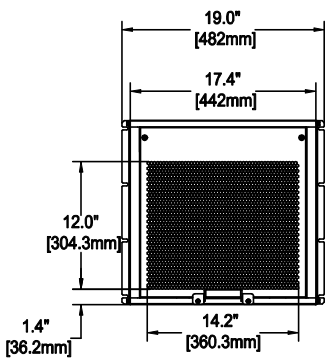

Front of Unit

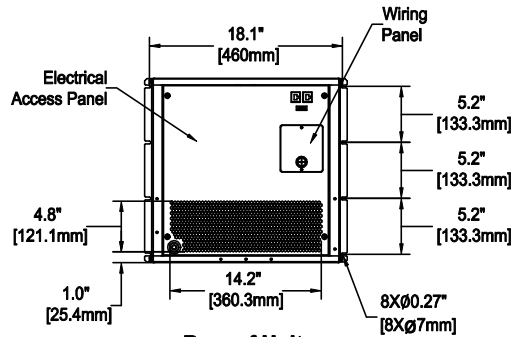

Rear of Unit

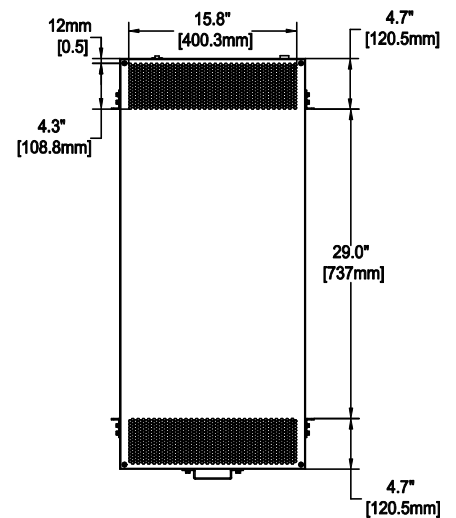

Top of Unit

MODEL #	MODULE WEIGHT
60 HZ	lbs. (kg) net
VRC100/101	143(65)

## ELECTRICAL FIELD CONNECTIONS

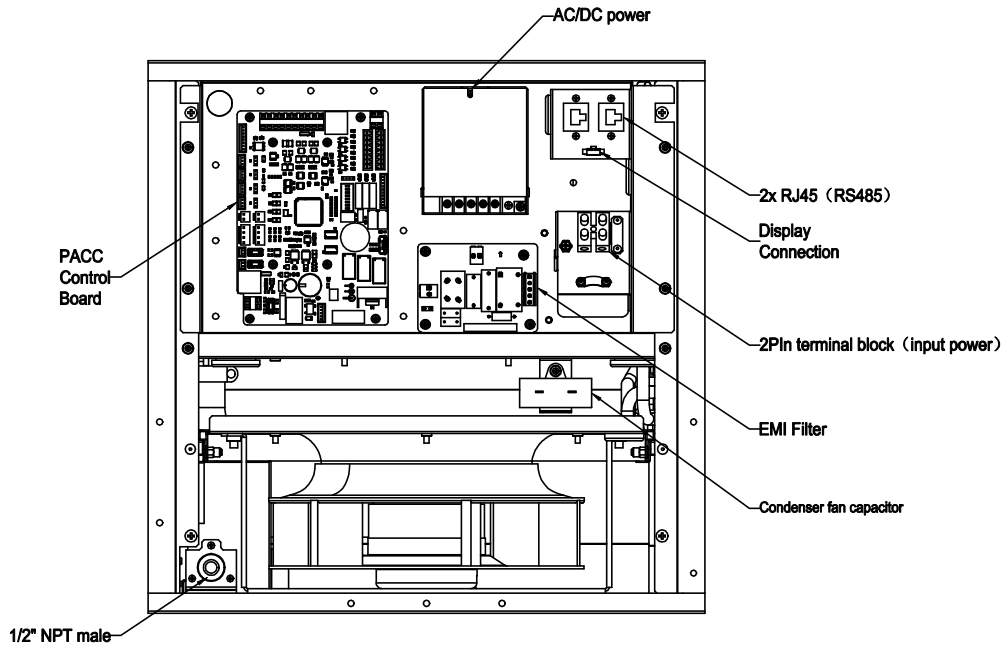

**Rear of Unit [ Panels removed for clarity ]  
Front of EP**