

TECHNICAL DATA SHEET - Vision•Point™ Desktop Articulating Arm for LCD Screens

For screens weighing 8 lb to 25 lb

peerless
Solid Solutions - Solid Support

MODELS: LCT 100, LCT 100P

The **LCT 100** and **LCT 100P** desktop arm allows for a full range of motion and continuous swivel.

Features:

- For LCD TVs and monitors from 8 lb to 25 lb
- Full range of motion: Bearing swivel base allows for a full 360° continuous swivel action of arm; 180° horizontal rotation from extension arm; 180° rotation and 88° pivot (spherical tilt) from socket clamp
- Gas spring cylinder allows user to move the screen sideways and upwards/downwards on the arm with a smooth continuous movement. Arm then holds the screen in place with no additional locking mechanism or knob
- Internal cord management in main arm
- Made of strong yet lightweight die-cast aluminum and thermoplastic resin
- Screen bracket features both 75 and 100 VESA standards
- Screen bracket attaches to and detaches from mount with quick release clamps for easy installation and switching of monitors
- Comes with optional removal restriction if quick release is not desired
- Arm must be combined with a mounting accessory below to make a complete unit; for wood and/or wood composite surfaces from 3/4" to 1.5" thick
- Colors: available in black (model LCT 100) or platinum (model LCT 100P)

Mounting Accessories:

- Stationary base: allows user to mount unit by drilling anywhere on mounting surface or by installing unit next to an existing desk grommet for cord management. Drilling required for both. Model **ACC 901** and **ACC 901P**
- C-clamp accessory: allows user to clamp arm onto side of mounting surface. No drilling required. Model **ACC 903** and **ACC 903P**

Other Accessories:

- Adapter plates for screens not featuring a VESA standard hole pattern

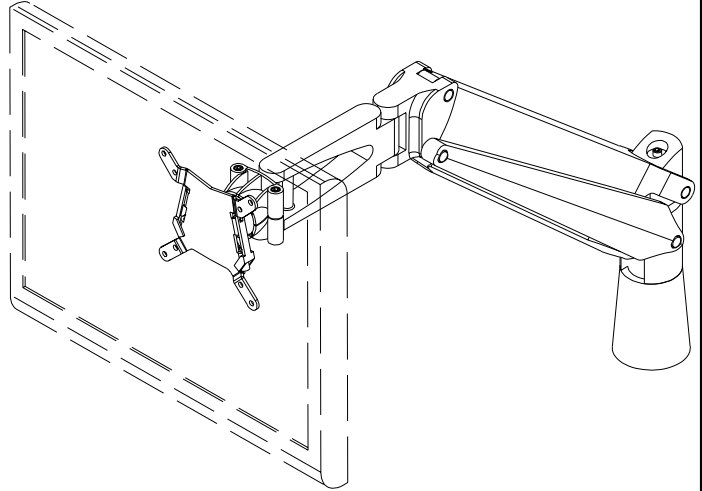

Dimensions:

Weight:

6.30 lb (2.9 kg)

Shipping weight:

7.30 lb (3.3 kg)

Load Capacity:

8.00 lb (3.6 kg) to 25.00 lb (11.4 kg)

Shipping Carton dimensions:

L= 25.8 in (654 mm)

W= 7.3 in (184 mm)

H= 3.0 in (76 mm)

ARCHITECTS SPECIFICATIONS

The Desktop Arm shall be Peerless models **LCT 100** and **LCT 100P** and shall be located where indicated on the plans. It shall feature 360° swivel action, 180° horizontal rotation, and 88° pivot with a gas spring cylinder for articulation. It shall be constructed of cast aluminum, sheet metal, and plastic parts. Assembly and installation shall be done according to instructions provided by the manufacturer.

Peerless Industries, Inc.

1980 Hawthorne Ave. Melrose Park, IL 60160
708-865-8870 800-865-2112 Fax 708-865-2941

www.peerlessindustries.com

ISSUED: 09-11-02 SHEET NO: 090-9545-1

©2002 Peerless Industries, Inc. All rights reserved.

Vision•Point is a trademark and Peerless is a registered trademark of Peerless Industries, Inc.

TECHNICAL DATA SHEET

MODELS: LCT 100, LCT 100P

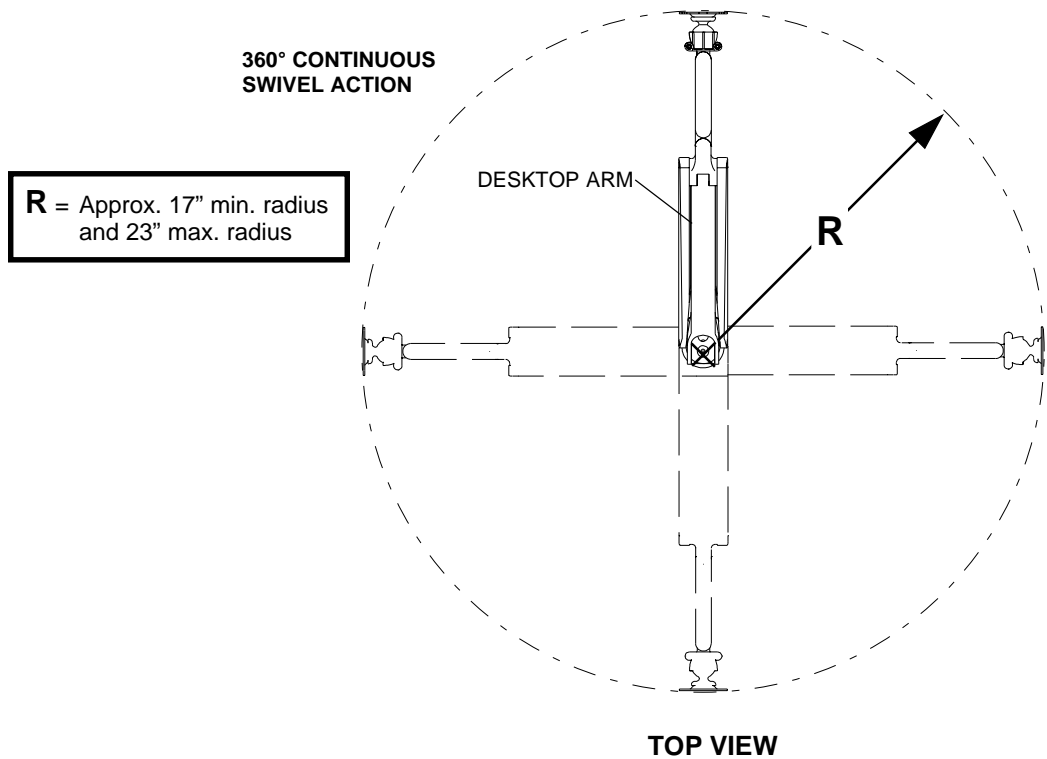
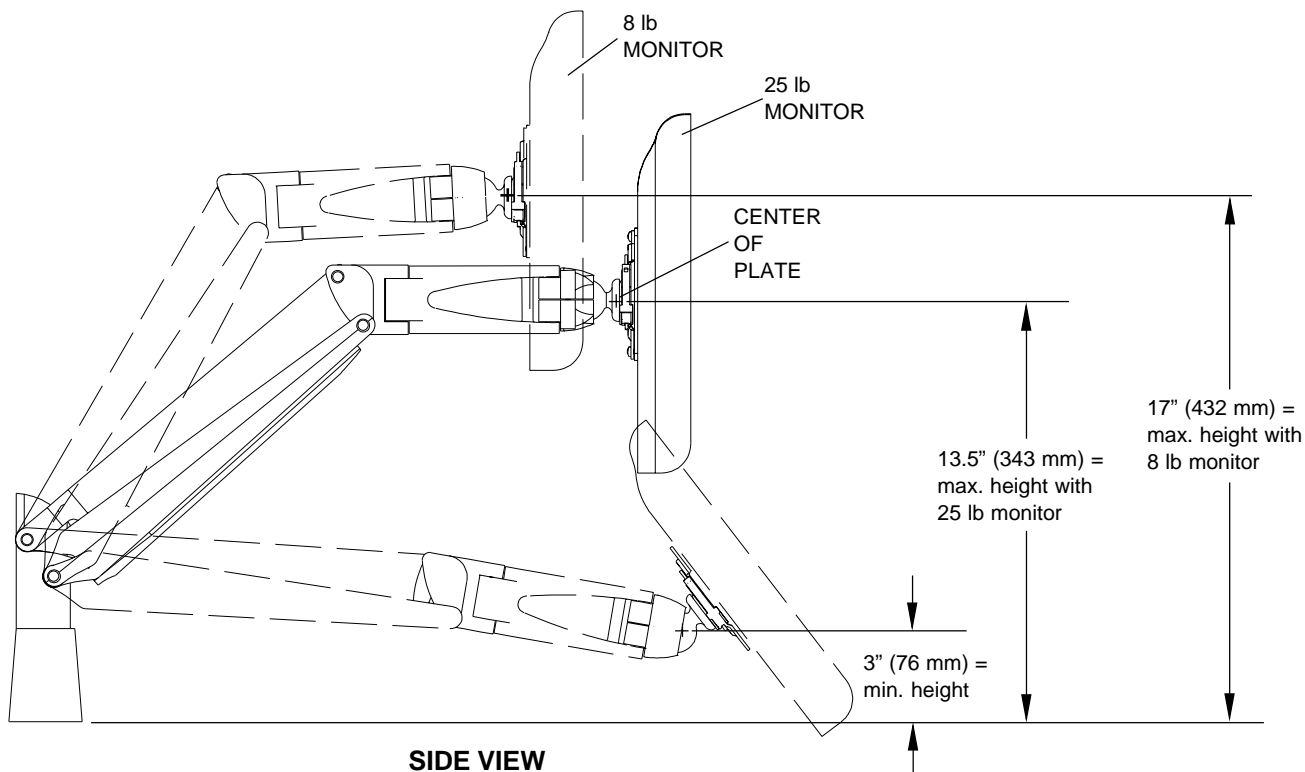

R = Approx. 17" min. radius and 23" max. radius

TECHNICAL DATA SHEET

MODELS: LCT 100, LCT 100P

